

	MANEUVER	COMMENT	Poss. Points	SCORE
A	Be ready at A, square stance, acknowledge judge			
A	Jog 2 strides from A		25	
B-C	Extend the jog to B around the square corner and to C		25	
C	Pick up the right lead and lope a small slow circle to the right		25	
C	Return to C and lope a larger circle with speed at C		25	
C-D	Continue on the right lead to D		25	
D	Stop at D. Turn 180 degrees to the right		25	
D	Jog a circle around D		25	
D	Stop at D and back approximately one horse length		25	
	Turn 360 degrees to the left		25	
	Follow the instructions of your ring steward to exit		25	
	Presentation of horse and rider		25	
	General horsemanship & fluidity		25	
Comments			Total	Score
			300	

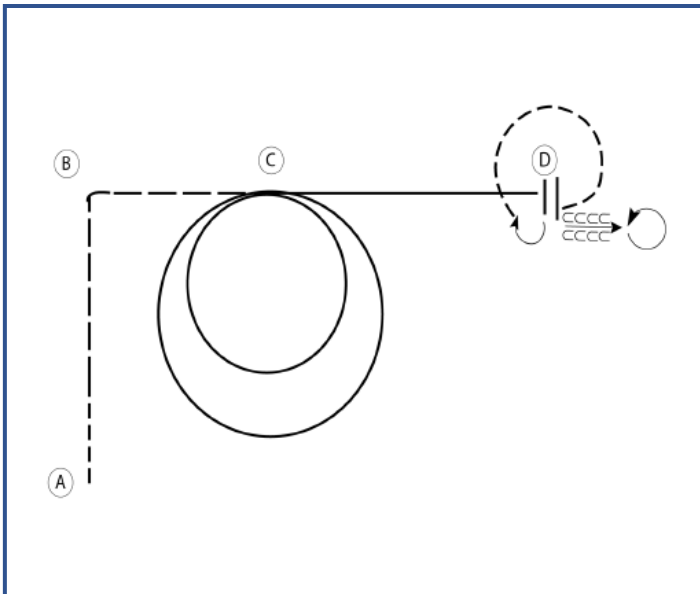

Judges Signature: _____

Date: _____
